

Technical Data Sheet

Series: **Kera**

Article code: **88CR5515 02**

Description:

One hole basin mixer, 1"1/4 pop up waste, antitorsion flex cm 50 x 1/2"F.

Materials:

Brass

Surface finish Chrome:

14 micron Nickel

0.3 microm Chrome

Finishings



CR

NN

BB

OZ

TT

CN

NP



Features



Cartridge diam. 35 mm with 2 ceramic disks, with 25° opening angle, and 90° mixing angle. We use only certified white lubricant into our mixers and cartridges.



Aerator Male thread 24 x 1
Flow rate 7 l/min at 3 bar



Stainless steel flex hoses cm 50 with 1/2 brass nut with internal non removable rubber



Metal 1"1/4 pop up waste



Easy installation with 65 mm brass long fixing screw
Suitable for electrical water heater

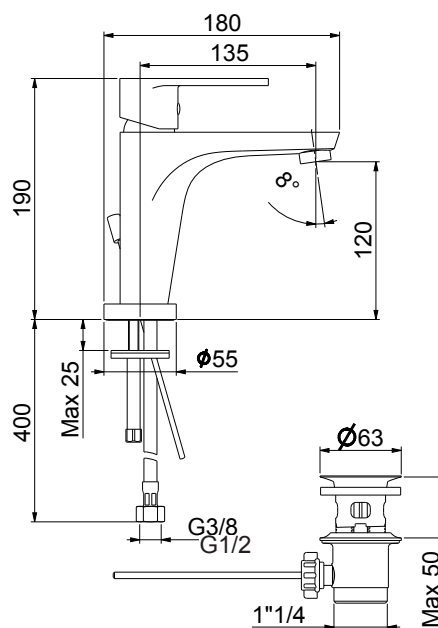

Technical Data Sheet

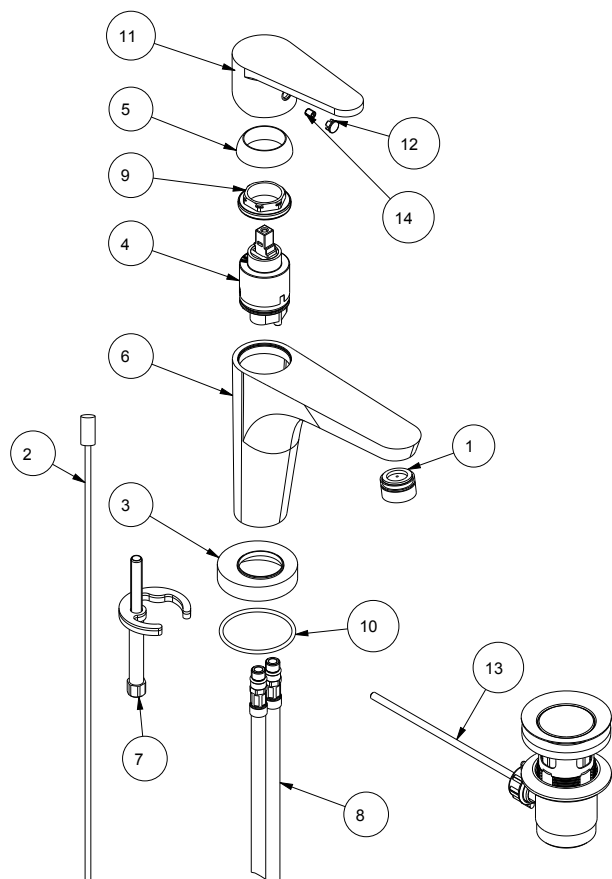

01	M24x1 aerator	Brass
02	Rod	Brass
03	Base	Brass
04	Cartridge d. 35	/
05	Cap	Chrome ABS
06	Body	Brass
07	Fixing set	/
08	Antitorsion flexible hoses 50 cm	/
09	Locking nut	Brass
10	OR	Rubber
11	Lever	Brass
12	Plaquette	Chrome ABS
13	1"1/4 pop up waste	/
14	Screw M5x6	Steel

Maintenance

Product care also includes regularly cleaning the aerator filter from impurities and/or lime scale. For correct decalcification, disassemble the aerator and place it into diluted vinegar (max concentration: 10% at 20°C) to remove lime scale deposits and/or dirt from the aerator filters. Leave it to soak for a few hours, and then rinse using only water.

Cleaning recommendation for products and care of finish

Chrome: the chrome surfaces can be cleaned with a mild detergent or with neutral soap and water.

Color finishes: taps with colored finishes should be cleaned only with a cloth and water.

Never use detergents containing mineral acids (ex. hydrochloric acid), aggressive acids (ex. acetic acid), bases (ex. ammonia) phosphoric acid or other aggressive substances, as they can cause significant damage.



www.fiore.it/catalogues